

Please check the examination details below before entering your candidate information

Candidate surname					Other names						
<b>Pearson Edexcel</b>											
<b>Level 3 GCE</b>											
Centre Number					Candidate Number						
<input type="text"/> <input type="text"/> <input type="text"/> <input type="text"/> <input type="text"/>					<input type="text"/> <input type="text"/> <input type="text"/> <input type="text"/> <input type="text"/>						
Time 2 hours					Paper reference		<b>9BN0/02</b>				
<b>Biology A (Salters Nuffield)</b>											
<b>Advanced</b>											
<b>PAPER 2: Energy, Exercise and Coordination</b>											
<b>You must have:</b> Ruler, pencil and calculator								Total Marks			

## Instructions

- Use **black** ink or ball-point pen.
- **Fill in the boxes** at the top of this page with your name, centre number and candidate number.
- Answer **all** questions.
- Show your working in any calculation questions and include units in your answer where appropriate.
- Answer the questions in the spaces provided  
– *there may be more space than you need.*

## Information

- The total mark for this paper is 100.
- The marks for **each** question are shown in brackets  
– *use this as a guide as to how much time to spend on each question.*
- You may use a scientific calculator.
- In questions marked with an **asterisk (\*)**, marks will be awarded for your ability to structure your answer logically, showing how the points that you make are related or follow on from each other where appropriate.

## Advice

- Read each question carefully before you start to answer it.
- Try to answer every question.
- Check your answers if you have time at the end.
- Good luck with your examination.

Turn over ►

P65460A

©2021 Pearson Education Ltd.

1/1/1/1/



Pearson

**Answer ALL questions.**

**Some questions must be answered with a cross in a box ☒. If you change your mind about an answer, put a line through the box ☒ and then mark your new answer with a cross ☒.**

- 1 All known organisms can be placed into one of the three domains of life.

The table shows some information about the three different domains.

Feature	Archaea	Bacteria	Eukaryota
DNA is circular	Yes	Yes	No
DNA is single-stranded	No	.....	No
Growth inhibited by the antibiotic streptomycin	No	Yes	No
Name of the link between fatty acids and glycerol in lipids	Ether	Ester	Ester
Presence of cell wall	Some	Yes	.....
Methionine required for starting protein synthesis	Yes	No	Yes
Transcription factors required for transcription	Yes	No	Yes

- (a) Complete the table to show the features in Bacteria and in Eukaryota.

(2)

DO NOT WRITE IN THIS AREA

DO NOT WRITE IN THIS AREA

DO NOT WRITE IN THIS AREA



(b) Explain how the information in the table can be used to show that the Archaea are more closely related to the Eukaryota than to the Bacteria.

(3)

DO NOT WRITE IN THIS AREA

DO NOT WRITE IN THIS AREA

DO NOT WRITE IN THIS AREA

.....

.....

.....

.....

.....

.....

.....

.....

.....

.....

.....

.....

.....

.....

.....

.....

.....

.....

.....

.....

.....

.....

.....

**(Total for Question 1 = 5 marks)**



2 Children are different from their parents due to genetic variation and other factors. Genetic variation can be the result of meiosis and random fertilisation of gametes.

(a) Describe how meiosis leads to genetic variation in the gametes produced. (2)

.....

.....

.....

.....

.....

.....

(b) During random fertilisation, only one sperm cell fuses with the cell surface membrane of an egg cell. Vesicles play an important role in this process. Explain how vesicles are involved in the successful fertilisation of an egg cell by only one sperm. (2)

.....

.....

.....

.....

.....

.....

.....

.....

.....

.....

DO NOT WRITE IN THIS AREA

DO NOT WRITE IN THIS AREA

DO NOT WRITE IN THIS AREA





**3** Mucopolysaccharides are complex molecules found in the human body.

(a) Mucopolysaccharides are large molecules containing unbranched polysaccharides.

Describe the structure of an unbranched polysaccharide.

(2)

.....

.....

.....

.....

.....

.....

.....

(b) Mucopolysaccharides can be broken down by enzymes.

Describe how an enzyme could break down the polysaccharide component of mucopolysaccharides.

(2)

.....

.....

.....

.....

.....

.....

.....

DO NOT WRITE IN THIS AREA

DO NOT WRITE IN THIS AREA

DO NOT WRITE IN THIS AREA



DO NOT WRITE IN THIS AREA

DO NOT WRITE IN THIS AREA

DO NOT WRITE IN THIS AREA

(c) Mucopolysaccharidosis type 1 (MPS 1) is a recessive genetic condition.

People with MPS 1 cannot break down mucopolysaccharides.

The pedigree diagram shows the inheritance of MPS 1 in a family.

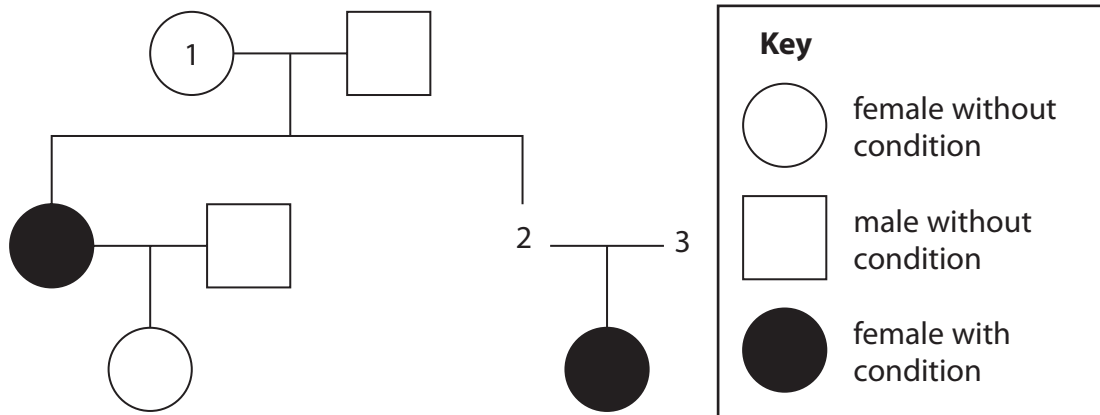

Determine the probability that person 2 has the same sex and MPS 1 phenotype as person 1.

(4)

.....

.....

.....

.....

.....

.....

.....

.....

**(Total for Question 3 = 8 marks)**



4 Scientists can use models to explain the need for a circulation system in animals.

- (a) The shapes in the diagram represent two different animals that live in water. The figures represent the height, width and breadth of the animals.

Determine why animal A does not need a circulation system but animal B does.

(4)

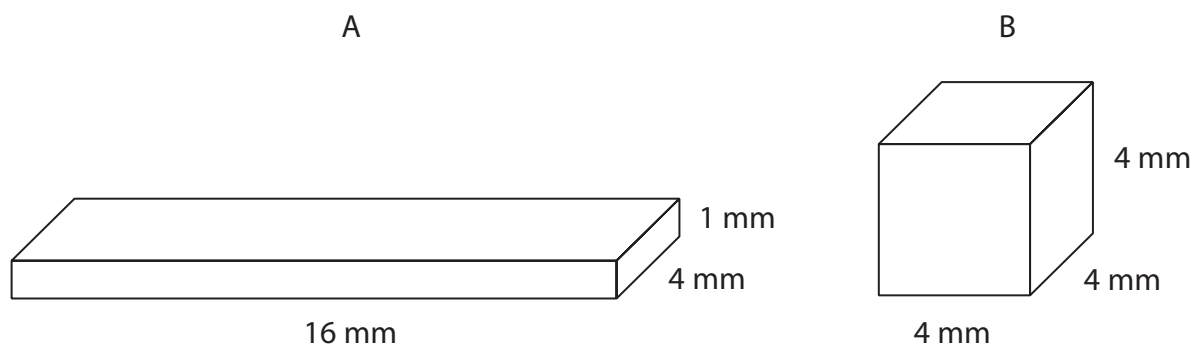

DO NOT WRITE IN THIS AREA

DO NOT WRITE IN THIS AREA

DO NOT WRITE IN THIS AREA





- (b) During the development of the mammalian heart, there is a hole between the left ventricle and the right ventricle.

This hole usually becomes sealed before the mammal is born. If it is not sealed, the mammal will become easily tired due to a lack of energy.

Explain why a mammal born with a hole between the two ventricles will have these symptoms.

(3)

.....

.....

.....

.....

.....

.....

.....

.....

.....

.....

- (c) In the lungs, oxygen moves from the alveoli into red blood cells.

- (i) How many times does an oxygen molecule cross a cell surface membrane to move from the centre of an alveolus to the centre of a red blood cell?

(1)

- A 2
- B 3
- C 4
- D 5

- (ii) Oxygen enters the red blood cell by

(1)

- A active transport
- B diffusion
- C facilitated diffusion
- D osmosis

**(Total for Question 4 = 9 marks)**



- 5 The cardiac cycle is the sequence of events in one heartbeat. In humans, the cardiac cycle can be divided into three stages.

(a) In the ventricular systole stage of the cardiac cycle, the

(1)

- A** ventricles contract, atrioventricular valves close and semilunar valves open
- B** ventricles contract, atrioventricular valves open and semilunar valves close
- C** ventricles relax, atrioventricular valves close and semilunar valves open
- D** ventricles relax, atrioventricular valves open and semilunar valves close

(b) Caffeine is a stimulant found in coffee.

The effect of different types of coffee on blood pressure was investigated. Decaffeinated coffee has most of the caffeine removed.

Four groups of volunteers had their blood pressure measured before having a drink and again 30 minutes later.

The results of this investigation are shown in the table.

Drink provided to volunteers	Mean systolic blood pressure / mm Hg	
	Before the drink	30 minutes later
Water	115	119
Decaffeinated coffee	120	118
Regular coffee	106	118

- (i) Calculate the percentage increase in the mean systolic blood pressure after drinking regular coffee.

(1)

..... %

DO NOT WRITE IN THIS AREA

DO NOT WRITE IN THIS AREA

DO NOT WRITE IN THIS AREA



(ii) *Daphnia* can be used to investigate the effects of caffeine on heart rate.

Devise a procedure to compare the effects of decaffeinated coffee and regular coffee on the heart rate of *Daphnia*.

(4)

DO NOT WRITE IN THIS AREA

DO NOT WRITE IN THIS AREA

DO NOT WRITE IN THIS AREA

Area with horizontal dotted lines for writing the procedure.



(c) Explain why high blood pressure can increase the risk of developing cardiovascular disease (CVD).

(3)

.....

.....

.....

.....

.....

.....

.....

.....

.....

.....

.....

.....

.....

.....

.....

.....

.....

.....

.....

.....

.....

.....

**(Total for Question 5 = 9 marks)**

DO NOT WRITE IN THIS AREA

DO NOT WRITE IN THIS AREA

DO NOT WRITE IN THIS AREA



DO NOT WRITE IN THIS AREA

DO NOT WRITE IN THIS AREA

DO NOT WRITE IN THIS AREA

**BLANK PAGE**



- 6 Spider silk is a very strong and flexible natural fibre. It is of interest to humans as a possible fibre for protective clothing.

Scientists have genetically modified a range of organisms to produce spider silk, including goats and plants such as alfalfa.

- (a) A gene for spider silk is copied. A gene for resistance to antibiotic A is also copied.

The flow diagram shows some of the stages in genetically modifying alfalfa plants to produce spider silk using the copied genes.

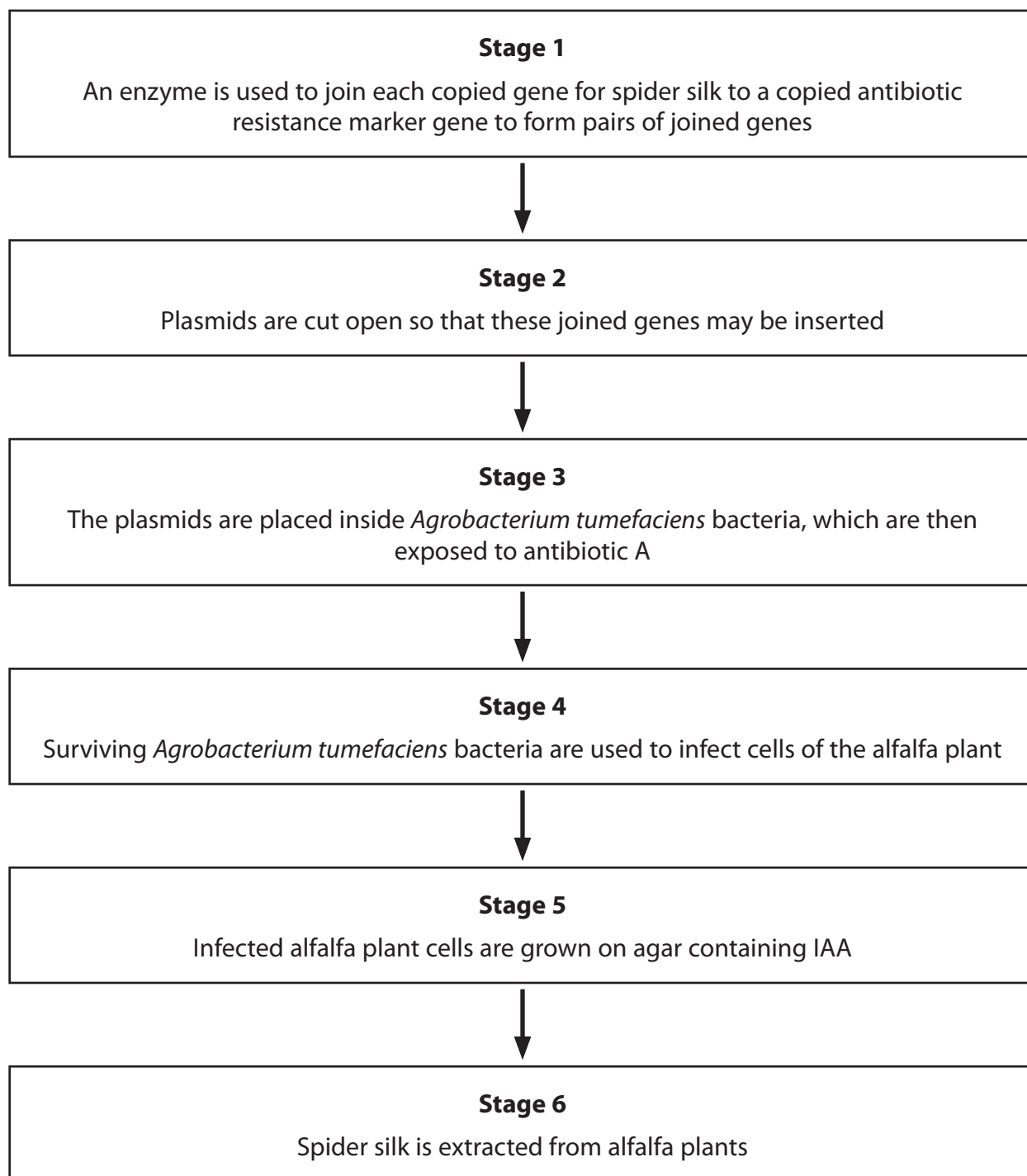

DO NOT WRITE IN THIS AREA

DO NOT WRITE IN THIS AREA

DO NOT WRITE IN THIS AREA



- (i) Explain how an enzyme is involved in joining the two different genes together in stage 1.

(3)

.....

.....

.....

.....

.....

.....

.....

.....

- (ii) Which one of the following enzymes can be used to cut open the plasmids in stage 2?

(1)

- A** DNA polymerase
- B** RNA ligase
- C** RNA polymerase
- D** restriction endonuclease

- (iii) Explain why antibiotic A is used in stage 3.

(2)

.....

.....

.....

.....

.....

.....

.....

.....

DO NOT WRITE IN THIS AREA

DO NOT WRITE IN THIS AREA

DO NOT WRITE IN THIS AREA



P 6 5 4 6 0 A 0 1 5 3 6

(iv) Give reasons why the infected alfalfa plant cells are grown on agar containing IAA in stage 5.

(2)

.....

.....

.....

.....

.....

.....

.....

.....

.....

.....

(v) The table shows the mass of spider silk produced from the genetically modified alfalfa in stage 6. It also shows the mass of spider silk produced from the genetically modified goats.

Organism	Mass of spider silk produced per year
Alfalfa	218 kg per acre
Goat	10 kg per goat

A typical number of goats that can be kept on one acre of land is 12.

Calculate the percentage increase in spider silk produced by the alfalfa plants compared with the goats.

(3)

..... %





(b) Give two reasons why some people may be concerned about the use of genetically modified alfalfa as a source of spider silk.

(2)

.....

.....

.....

.....

.....

.....

.....

.....

.....

.....

.....

.....

.....

.....

.....

.....

.....

.....

.....

.....

.....

.....

**(Total for Question 6 = 13 marks)**

DO NOT WRITE IN THIS AREA

DO NOT WRITE IN THIS AREA

DO NOT WRITE IN THIS AREA



DO NOT WRITE IN THIS AREA

DO NOT WRITE IN THIS AREA

DO NOT WRITE IN THIS AREA

**BLANK PAGE**



7 Moving a limb involves the interaction of muscles, tendons and ligaments.

(a) Muscles can contain fast twitch and slow twitch muscle fibres.

(i) Describe two structural differences between fast twitch muscle fibres and slow twitch muscle fibres.

(2)

.....

.....

.....

.....

.....

.....

.....

.....

.....

(ii) Muscles can be extensors or flexors.

Which of the following correctly describes the state of the muscles described?

(1)

	When the arm is bent at the elbow, the flexor muscle is	When the lower leg is straightened at the knee, the flexor muscle is
<input type="checkbox"/> A	contracted	contracted
<input type="checkbox"/> B	contracted	relaxed
<input type="checkbox"/> C	relaxed	contracted
<input type="checkbox"/> D	relaxed	relaxed



(b) Tendons and ligaments are important structures in elbow and knee joints.

(i) Which of the following identifies the structures that join bones to bones in an elbow joint?

(1)

- A** ligaments only
- B** ligaments and tendons
- C** tendons only
- D** neither ligaments nor tendons

(ii) One type of joint injury is a torn ligament. This may be treated by adding a piece of tendon to the ligament. This is because after a period of time, the tendon tissue changes and responds in the same way as a ligament.

Which of the rows in the table correctly describe the changes in this piece of tendon?

(1)

Row	Piece of tendon shows a change in its	The change is
1	genotype	an anatomical adaptation
2	genotype	a physiological adaptation
3	phenotype	an anatomical adaptation
4	phenotype	a physiological adaptation

- A** row 1 only
- B** row 3 only
- C** rows 1 and 2
- D** rows 3 and 4



\*(iii) The photograph shows athletes competing in the modern triathlon.

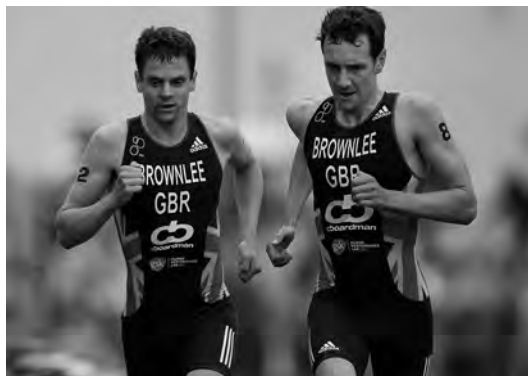

© Gonzalo Arroyo Moreno / Stringer

The modern triathlon involves three sports: swimming, cycling and running.

An investigation was carried out to compare the level of demand on the body of these three sports during a triathlon.

The investigation involved 12 athletes who were all males of the same age.

Each athlete carried out the triathlon as shown in the flow diagram. There was no rest period between each sport.



The heart rate for each athlete was measured as they completed each sport.

The mean heart rate for each sport was then calculated and is shown in the table.

Sport	Mean heart rate / bpm
Swimming	163
Cycling	165
Running	159



The blood lactate level for each athlete was also measured as they completed each sport. Means for lactate level after each sport were calculated.

The results are shown in the graph.

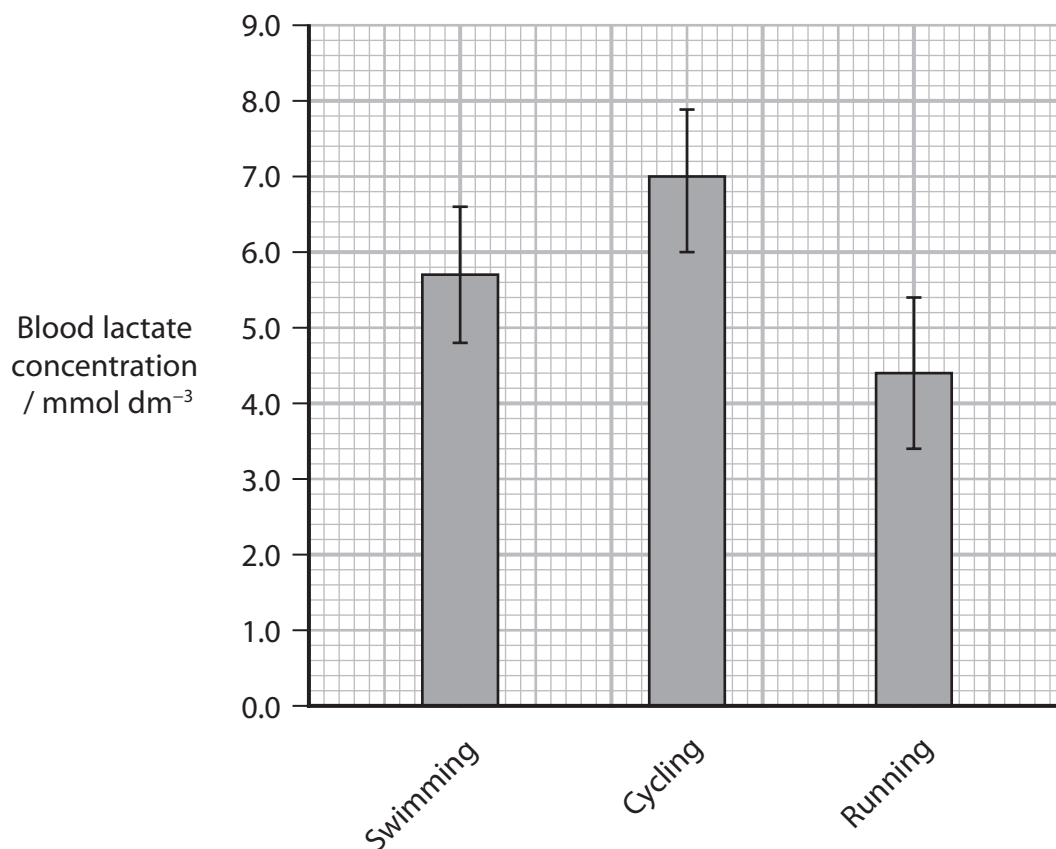

It was concluded that cycling was the most demanding of the three triathlon sports. This was followed by swimming and then running.

Evaluate the validity of this conclusion.

(6)

.....

.....

.....

.....

.....

.....

.....

.....

.....

.....



DO NOT WRITE IN THIS AREA

DO NOT WRITE IN THIS AREA

DO NOT WRITE IN THIS AREA

(Total for Question 7 = 11 marks)



8 Yeast is a single-celled organism that can respire aerobically.

Mitochondria are the sites of aerobic respiration in yeast cells.

(a) The diagram shows a mitochondrion.

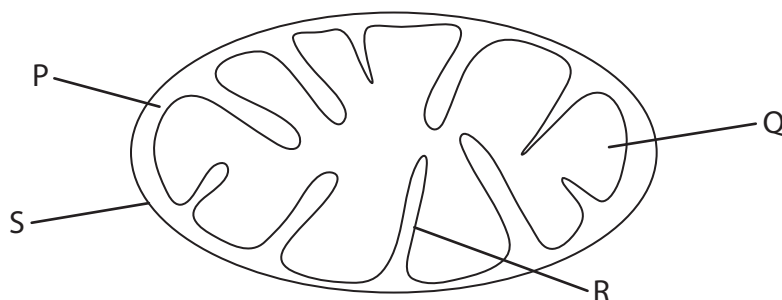

(i) Which labelled component in the diagram is the site of the Krebs cycle?

(1)

- A P
- B Q
- C R
- D S

(ii) Which labelled component in the diagram is the site of oxidative phosphorylation?

(1)

- A P
- B Q
- C R
- D S

(iii) Yeast cells can have many small mitochondria.

Calculate the magnification of the diagram if the maximum length of the mitochondrion is  $0.5\ \mu\text{m}$ .

(2)

Answer .....









DO NOT WRITE IN THIS AREA

DO NOT WRITE IN THIS AREA

DO NOT WRITE IN THIS AREA

**BLANK PAGE**



- 9 When astronauts are in space, the force of gravity is less than when they are on a planet such as Earth or Mars.

Scientists need to investigate how varying gravity affects astronauts.



NASA/Science photo library

In one investigation, scientists grew human muscle cells in culture.

These cells were split into two groups:

- Group 1 was taken into space for 10 days
- Group 2 remained on Earth for 10 days.

Data were collected on protein synthesis and protein breakdown in each group of cells.

(a) State why data were collected for Group 2 as well as for Group 1.

(1)

.....

.....

.....

.....

DO NOT WRITE IN THIS AREA

DO NOT WRITE IN THIS AREA

DO NOT WRITE IN THIS AREA



(b) The scientists proposed a null hypothesis for the rate of breakdown of protein in the muscle cells of the two groups.

The data from this investigation showed that there was no significant difference at the 0.05 probability level.

(i) Explain what is meant by no significant difference at the 0.05 probability level for the rate of breakdown of protein.

(2)

DO NOT WRITE IN THIS AREA

DO NOT WRITE IN THIS AREA

DO NOT WRITE IN THIS AREA

.....

.....

.....

.....

.....

.....

.....

(ii) Some of the myosin in the muscle cells was broken down.

Describe how the tertiary structure of myosin is related to its function.

(3)

.....

.....

.....

.....

.....

.....

.....

.....

.....

.....

.....

.....

.....

.....

.....

.....

.....

.....

.....

.....

.....

.....

.....





DO NOT WRITE IN THIS AREA

DO NOT WRITE IN THIS AREA

DO NOT WRITE IN THIS AREA

Area with horizontal dotted lines for writing.

**(Total for Question 9 = 12 marks)**



- 10** The retina of the human eye contains rod cells.  
These cells detect light energy as photons.  
The light energy is converted to a nerve impulse that is interpreted by the brain.

(a) A current is produced by a rod cell when ions move through the cell surface membrane of a rod cell.

The graph shows the effect of increasing light intensity on the current produced by a rod cell.

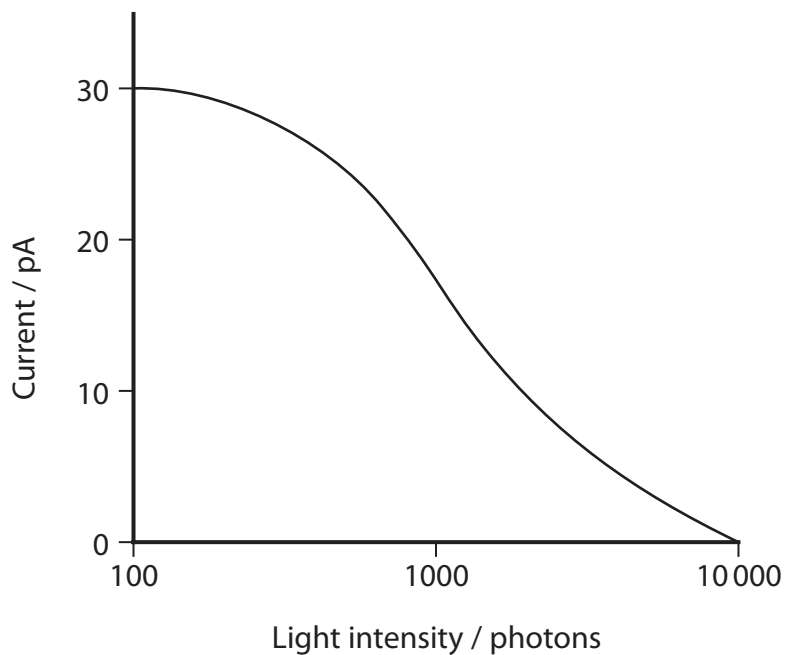

DO NOT WRITE IN THIS AREA

DO NOT WRITE IN THIS AREA

DO NOT WRITE IN THIS AREA





Explain the effect of increasing light intensity on the current produced by a rod cell.

(5)

DO NOT WRITE IN THIS AREA

DO NOT WRITE IN THIS AREA

DO NOT WRITE IN THIS AREA

Area with horizontal dotted lines for writing.



P 6 5 4 6 0 A 0 3 3 3 6

(b) (i) The transmission of an impulse between a neurone in the optic nerve and a cell in the brain involves ions and neurotransmitter molecules.

Describe how these ions and neurotransmitter molecules are involved in the transmission of an impulse.

(4)

.....

.....

.....

.....

.....

.....

.....

.....

.....

.....

.....

.....

.....

.....

.....

.....

DO NOT WRITE IN THIS AREA

DO NOT WRITE IN THIS AREA

DO NOT WRITE IN THIS AREA



(ii) The diagram shows a human brain.

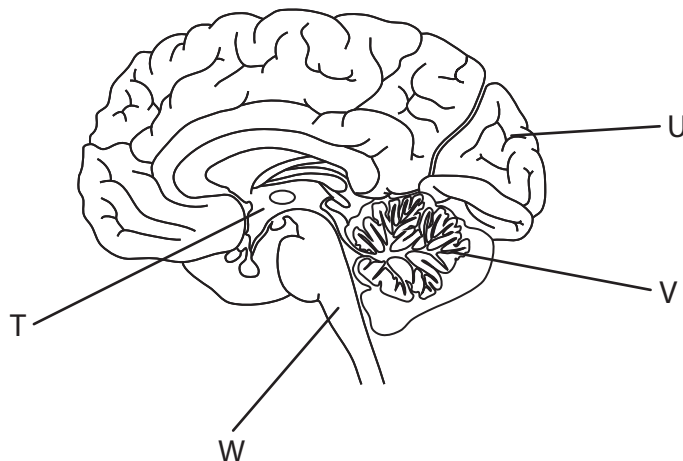

Which label on the diagram identifies the area of the brain where an image is interpreted?

(1)

- A T
- B U
- C V
- D W

DO NOT WRITE IN THIS AREA

DO NOT WRITE IN THIS AREA

DO NOT WRITE IN THIS AREA



